

EFFECT OF PRE-COAGULATION CONDITION ON CERAMIC MEMBRANE FILTRATION

Naoki MURATA ^{1,2*}, Nobuhiro AOKI ², Fusheng LI ¹
Hitoshi YONEKAWA ³, Nobuyuki MOTOYAMA ²

¹ Graduate School of Engineering, Gifu University.
(1-1 Yanagido, Gifu 501-1193, Japan)

² R&D Center, METAWATER Co.,Ltd.

(Maegata-cho 1, Handa, Aichi 475-0825, Japan)

³ Engineering Division, METAWATER Co.,Ltd.
(2-56 Suda-cho, Mizuho, Nagoya 467-8530, Japan)

* E-mail: murata-naoki@metawater.co.jp

Application of membrane filtration processes in large-scale water treatment facilities has expanded in recent years. In particular, they are increasingly used for surface water treatment (river and lake waters) rather than for groundwater treatment. Generally, coagulation is used to remove colloidal and suspended particles in surface water, but the effects of coagulation, which is a pre-treatment process in membrane filtration, on membrane fouling are scarcely reported. In this research, we studied the effect of coagulation as a pretreatment process of the ceramic membrane filtration system, with the focus being concentrated on investigation of the effect of Gt value of coagulation through experiments of membrane filtration after pre-coagulation. The results indicate that; the difference in the increase rate of transmembrane pressure depends on the Gt-value of coagulation. The optimum Gt values seem to be existent in the range of 20,000-50,000. Optimization of the Gt-value contributes to suppression of the increase rate of the transmembrane pressure, reduction of the coagulant dosage and reduction of pH control chemicals.

Key Words : ceramic membrane filtration, coagulation, G-value, Gt-value, transmembrane pressure

1. INTRODUCTION

Control of membrane fouling in the course of filtration is of substantial importance in the application of membrane filtration for surface water treatment. Some studies have indicated that coagulation is an effective pretreatment process that can alleviate membrane fouling and at the same time remove a certain percentage of humic substances [1-3]. However, there are also several studies that found that coagulation pretreatment worsened membrane fouling [4-6]. It has been reported that using coagulation conditions appropriate for the conventional chemical precipitation process could not lead to optimum performance for membrane filtration [7]. Based on the results of a series of bench-scale membrane (pore size 0.1 μ m) filtration experiments, which used feed water containing commercially available humic acid or organic matter

isolated from surface water after coagulation with polyaluminum chloride (PACl) under various conditions, Kimura *et al.* found that coagulation conditions had great impacts on the degree of physically irreversible fouling [8]. Acidic coagulation conditions were found to be able to improve the quality of treated water but generally cause greater physically irreversible fouling than coagulation under neutral or alkaline conditions. The dosage of coagulant was also found to affect the extent of membrane fouling, with higher dosage revealing more severe irreversible fouling. The difference in the physicochemical characteristics of flocs, such as the sizes and the affinity with membrane, formed under different coagulation conditions is a likely reason behind the difference in the extent of membrane fouling. Regarding floc sizes and its affinity with membrane, in addition to the coagulant dose and pH, mixing strength and time of the coagulation process are also important

Table 1 Kiso River raw water quality during the study period

	Unit	Maximum	Minimum	Average	Median	Number of samples
pH	—	8.3	6.5	7.2	7.1	90
Turbidity	mg/L	68.0	0.5	5.8	3.9	95
Color	degree	11.0	0.6	2.6	2.3	93
Total Fe	mg/L	1.40	0.02	0.15	0.11	90
Soluble Fe	mg/L	0.18	<0.01	0.03	0.02	89
Total Mn	mg/L	0.080	0.004	0.017	0.014	90
Soluble Mn	mg/L	0.014	0.001	0.003	0.002	89
Total Al	mg/L	1.50	0.04	0.17	0.12	95
Soluble Al	mg/L	0.26	0.01	0.03	0.02	91
TOC	mg/L	4.2	0.6	1.9	2.0	93
DOC	mg/L	2.7	0.5	1.1	1.0	88
UV260	1/5cm	0.446	0.058	0.141	0.130	94

controlling factors. However, little is known on how these factors affect membrane fouling when coagulation is used as the pretreatment process of membrane filtration, and pilot scale investigation is very scarce.

In this study, combined coagulation-membrane filtration process experiments were conducted using Kiso River water, an important drinking water source for water purification plants in the central Japan Aichi Prefecture, as the raw water to be treated. By varying the G-value and the mixing time t within the broader ranges ($G=30-1375\text{ s}^{-1}$, $t=1.5-600\text{ sec}$), the impact of coagulation on membrane performance was investigated. The effect of optimization of the coagulation condition on the performance of filtration during raw water quality variations induced by rainfall, for instance, was also discussed.

2. MATERIALS AND METHODS

(1) Raw water

Kiso River water that entered a water purification plant with the conventional rapid sand filtration

system was used as the raw water. The quality of the raw water during this study is summarized in **Table 1**. The quality of the river water is generally good. During the period of this study, the median values of turbidity, color and DOC were 3.9 NTU, 2.3 degree, 1.0 mg/L, respectively. The maximum values of turbidity, color and DOC, reaching 68.0 (NTU), 11.0 degree and 2.7 mg/L, respectively, were measured only after a heavy rainfall. The quality analysis was conducted according to the Standard Methods for Examination of Water [9].

(2) Membrane

Ceramic membrane having a nominal pore size of $0.1\text{ }\mu\text{m}$ was used. The detailed information on the specifications of this membrane is shown in **Table 2**.

(3) Experiment units and conditions

Three identical membrane filtration experiment units, each having a configuration as the one depicted in **Figure 1**, were designed and operated in parallel for investigation of the effect of pre-coagulation treatment conditions. Each unit

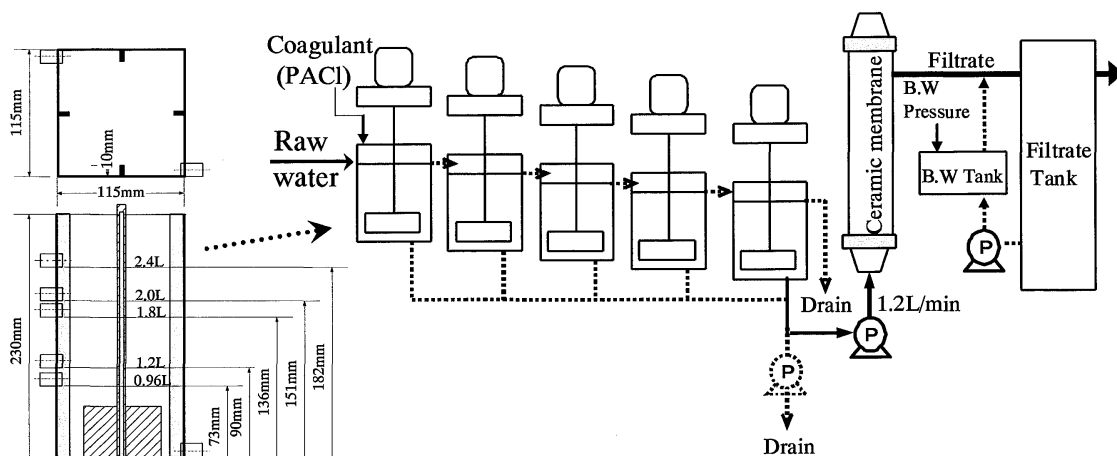

Fig. 1 Experiment unit

comprised of five mixing chambers and a ceramic module inserted with the membrane described in **Table 2**. On the left side wall of each chamber, five openings were designed at different vertical levels. By selecting the opening for use, the water level in each chamber can be changed. This allowed more flexible adjustment of the mixing time for the whole coagulation system, in addition to the adjustment based on the number of chambers to be used among the total five installed. Raw water after coagulation was pumped to the membrane module under a constant flow rate.

Polyaluminum chloride (PACl; basicity 54%, Al₂O₃ 10.0%) was used as the coagulant and was added to the first chamber with a constant dosage of 20 mg/L for all filtration runs. The mixing strength, described by G value (s⁻¹), was changed by adjusting the rotation speed of the mixing blade installed in each mixing chamber. The mixing time t (sec) was varied by changing the number of mixing chambers and the water level of each chamber to be used. Membrane filtration was terminated before the transmembrane pressure (TMP) reached about 100 kPa. The increasing rate of TMP (kPa/d) was estimated based on the initial TMP after backwashing and the TMP increasing profile with the least-square analysis method. Water pH was controlled by adding diluted sulfuric acid to the raw water to maintain the value of pH after addition of PACl at 6.8 [9]. Additional pretreatment, such as pre-chlorination and chemical backwashing, was not used for all experiment runs.

The general experiment conditions are summarized in **Table 3**, and the specific mixing conditions of coagulation for all experiment runs are listed in **Table 4**. Totally 18 experiment runs (Run 1 - Run 18) were conducted in order over the whole study period (2006/8/25 - 2008/4/28). The average

Table 2 Membrane specifications

Parameter	Ceramic MF
Nominal pore size	0.1 μm
Length / Diameter	1m / 0.03m
Channels per membrane	55
Channel diameter	2.5 mm
Membrane area	0.43 m ²
Pure water flux	45 m/d (at 25°C, 100kPa)

operation time for each run was about 30 days. In most cases, each run was further consisted of three series runs (Series A - Series C) operated in parallel for comparison of the effect of the mixing strength and the mixing time t within the ranges of G =30-1375 s⁻¹ and t=1.5-600 sec. Different combinations of G and t within the ranges were selected, which enabled generation of membrane filtration results related to the Gt values in the broader range of 2060-180,000. Experiment runs with very short mixing time but very strong mixing strength, for instance the run at t=2.5 sec and G=1375 s⁻¹ (Run 4 / Series B) could probably show the membrane performance when coagulation was insufficient to have substances causing irreversible membrane fouling, for instance, humic molecules, be captured onto/into flocs that can be rejected by membrane filtration. On the other hand, experiment runs with longer mixing time but weaker mixing strength, for instance, the run at t=600 sec and G=30 s⁻¹ (Run 16 / Series B) may generate information for the condition when irreversible fouling causing substances are captured onto/into probably fragile and less dense flocs containing more aluminum originated from the added coagulant.

For all runs, Series A that was operated under the same mixing condition (G= 110 s⁻¹, t=600 sec) was

Table 3 Experiment conditions

Coagulant dosage	20 mg/L (as PACl)
Coagulation tank pH	6.8 (controlled)
G value [s ⁻¹]	30, 100, 110, 300, 400, 500, 600, 1375
Rotation speed [rpm]	40 - 500
Mixing time, t [s]	1.5, 2.5, 30, 40, 45, 48, 60, 100, 300, 600
Gt value [-]	2060, 3440, 9000, 15000, 18000, 28800, 30000, 40000, 50000, 55000, 61875, 66000, 82500, 90000, 123750, 180000
Membrane filtration flux [m ³ /m ² /d]	4.0
Physical cleaning	Combined backwash (<0.5MPa) and air flushing (<0.2MPa)
Physical cleaning interval	3 hours

Table 4 Transmembrane pressure (TMP) development for all filtration runs

Run No.	Series No.	G value [s ⁻¹]	Mixing time, t [sec]	Gt value [-]	TMP increase rate [kPa/d]	Relative TMP increase rate [-] *	Run period
1	A	110	600	66000	1.01		2006/8/25-9/25
1	C	300	600	180000	1.32	1.31	2006/8/25-9/25
2	A	110	600	66000	2.53		2006/10/6-10/26
2	B	300	300	90000	2.75	1.10	2006/10/6-10/26
2	C	1375	90	123750	3.17	1.25	2006/10/6-10/26
3	A	110	600	66000	2.53		2006/10/26-11/30
3	C	1375	40	55000	3.33	1.32	2006/10/26-11/30
4	A	110	600	66000	1.43		2006/11/30-12/21
4	B	1375	2.5	3438	1.98	1.38	2006/11/30-12/21
4	C	1375	60	82500	1.14	0.80	2006/11/30-12/21
5	A	110	600	66000	1.43		2007/1/12-2/7
5	B	1375	60	82500	1.14	0.80	2007/1/12-2/7
5	C	1375	48	66000	1.43	1.00	2007/1/12-2/7
6	A	110	600	66000	1.74		2007/2/7-3/5
6	B	1375	45	61875	2.55	1.47	2007/2/7-3/5
6	C	1375	48	66000	1.78	1.02	2007/2/7-3/5
7	A	110	600	66000	1.16		2007/3/9-4/12
7	B	1375	48	66000	1.10	0.95	2007/3/9-4/12
8	A	110	600	66000	3.70		2007/4/12-5/7
8	B	300	30	9000	4.80	1.30	2007/4/12-5/7
8	C	600	48	28800	2.90	0.78	2007/4/12-5/7
9	A	110	600	66000	1.06		2007/5/16-6/5
9	B	1375	1.5	2060	2.24	2.11	2007/5/16-6/5
9	C	1375	60	82500	1.10	1.04	2007/5/16-6/5
10	A	110	600	66000	3.60		2007/6/22-7/25
10	B	600	30	18000	2.43	0.68	2007/6/22-7/25
11	A	110	600	66000	2.90		2007/7/27-8/23
11	C	500	30	15000	3.50	1.21	2007/7/27-8/23
12	A	110	600	66000	3.40		2007/8/23-9/14
12	B	500	30	15000	3.80	1.14	2007/8/23-9/14
12	C	100	500	50000	3.05	0.90	2007/8/23-9/14
13	A	110	600	66000	1.64		2007/9/14-10/17
13	B	300	100	30000	1.23	0.75	2007/9/14-10/17
13	C	500	60	30000	1.30	0.79	2007/9/14-10/17
14	A	110	600	66000	3.07		2007/10/17-11/13
14	B	100	500	50000	2.76	0.90	2007/10/17-11/13
14	C	500	100	50000	1.68	0.55	2007/10/17-11/13
15	A	110	600	66000	1.51		2007/11/26-12/26
15	B	300	600	180000	1.37	0.91	2007/11/26-12/26
15	C	400	100	40000	1.08	0.72	2007/11/26-12/26
16	A	110	600	66000	0.89		2008/1/8-2/8
16	B	30	600	18000	0.77	0.87	2008/1/8-2/8
16	C	400	100	40000	0.86	0.97	2008/1/8-2/8
17	A	110	600	66000	2.01		2008/2/12-3/3
17	B	30	600	18000	1.65	0.82	2008/2/12-3/3
17	C	400	100	40000	1.67	0.83	2008/2/12-3/3
18	A	110	600	66000	2.92		2008/4/1-4/28
18	C	400	100	40000	2.80	0.96	2008/4/1-4/28

* Relative TMP increase rate is the rate difference when the TMP increase rate of the reference series A in each filtration run is assumed as "1", which equals to the ratio of the TMP increase rate of series B and/or C to that of the reference series A in each filtration run.

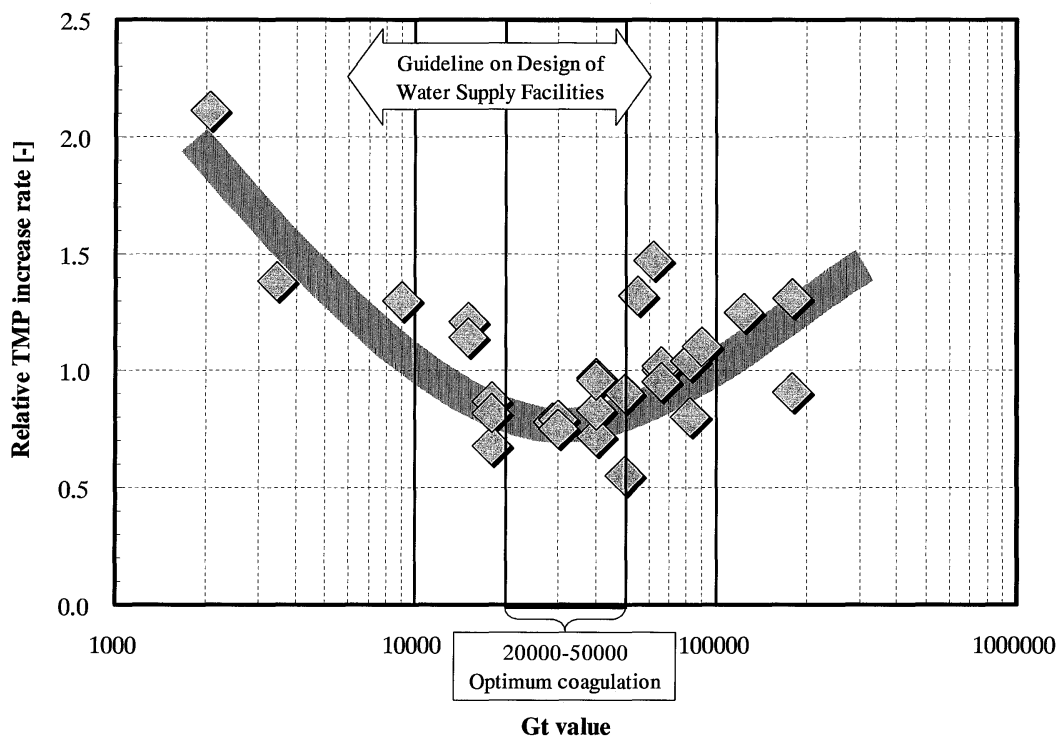

Fig. 2 Optimum coagulation range for membrane filtration

included. This series was used as the reference for comparing the effect of the mixing conditions since the quality of raw water from Kiso River fluctuated with time throughout the study period. The mixing condition for Series A was determined based on the result of a bench scale membrane filtration experiment for controlling of membrane filtration resistance by coagulation [10]. The G value was calculated using the following equation [10]:

$$G = \sqrt{\frac{\rho \cdot C \sum i(a_i v_i^3)}{2\mu V}}$$

ρ : Water density ($=1.0 \times 10^3 \text{ kg/m}^3$, 20°C)

C : Coefficient of resistance of mixing blade ($=1.5$)

a_i : Area of the mixing blade i , which is perpendicular to rotating direction (m^2)

v_i : Average speed of the mixing blade i (m/s)

μ : Water viscosity ($=1.0 \times 10^{-3} \text{ kg/m} \cdot \text{s}$, 20°C)

V : Mixed water volume (m^3)

3. RESULTS AND DISCUSSION

(1) Effect of mixing conditions of coagulation on TMP development

The values of the increasing rate of TMP for all

filtration runs under different combinations of the mixing strength G and the mixing time t are summarized in **Table 4**. For the reference runs of Series A, the TMP increase rate differed obviously, with the smallest and the largest rate values being 0.89 and 3.7 kPa/day for Run 16 / Series A and Run 8 / Series A, respectively. This difference was considered to be mainly caused by fluctuations in the raw water quality as could be seen from **Table 1**.

To evaluate the impact of mixing strength and mixing time on the development of TMP, the relative TMP increase rate, a parameter reflecting the relative increase of TMP was adopted. This parameter was computed by dividing the TMP increase rate of Series B and/or C by that of the reference run Series A. The computed values for all runs are also summarized in **Table 4**, and are plotted in **Figure 2** to show the relationship between TMP development and Gt value. In the Guideline on Design of Water Supply Facilities [11], a rapid mixing G value range of $100\text{-}200 \text{ s}^{-1}$ and a mixing time t range of $60\text{-}300 \text{ sec}$ are suggested [11]. This corresponds to a Gt range in $6,000\text{-}60,000$, which is also revealed in **Figure 2**. As is evident from this figure, an optimum coagulation range that could suppress the TMP increase rate seemed to be existent in the Gt range about $20,000\text{-}50,000$. Small Gt values (below

10,000) were found ineffective in suppressing the irreversible TMP development. This could be easily seen from the results with the runs of Run 4 / Series B ($G=1375 \text{ s}^{-1}$, $t=2.5 \text{ sec}$) and the Run 9 /Series B ($G=1375 \text{ s}^{-1}$, $t=1.5 \text{ sec}$). As shown in Table 4, for these two runs, even if the largest mixing strength ($G=1375 \text{ s}^{-1}$) was adopted, since the mixing time was too short (2.5 and 1.5 sec), the resulting relative TPM increase rate was comparatively larger: 1.38 and 2.11, respectively. Insufficient coagulation that probably failed to capture irreversible fouling-causing substances, such as larger humic molecules and fine turbid particles that could form flocs with other coexisting impurities under optimum coagulation conditions, was a likely reason behind. Li et al. studied the characteristics of micro-flocs of peaty water NOM coagulated by PACl and found that at the G value of 660 s^{-1} , the distribution of micro flocs ($0.1\text{-}5.0 \mu\text{m}$) could reach steady stage after rapid mixing for 30 sec and increasing the mixing time till 300 sec increased the captured NOM content (i.e., the ratios of UV260/Al and DOC/Al) in flocs with sizes above $5 \mu\text{m}$, the major floc fraction in the final solution after coagulation at pH 5.5 [13].

It is also interesting to find that for the run (Run 16 / Series B), even if the G value was very small ($G=30$

s^{-1}), the smallest investigated in this study, a mixing time of 600 sec led to a lower relative TMP increase rate (the rate value of 0.87). The Gt value under this condition was 18,000, close to the optimum Gt range mentioned above. Increasing the mixing time probably enhanced the capture of irreversible fouling-causing humic molecules (by sorption, for instance) onto /into fragile and less dense aluminum flocs formed under weaker mixing strength.

Membrane fouling involves complicated mechanisms. This is particularly true when membrane filtration is applied to treat surface water that contain a polydisperse mixture of impurities, many of which are not yet clarified. The optimum range obtained in this study may serve as an important reference for determining the coagulation conditions for practical application of membrane filtration to surface water; however, the mechanisms behind have to be clarified in coming studies through combined investigation of the floc characteristics and the physicochemical features of non-coagulated constituents remaining in water under different coagulation conditions. For this, bench scale membrane filtration experiments will be conducted along with pilot scale studies.

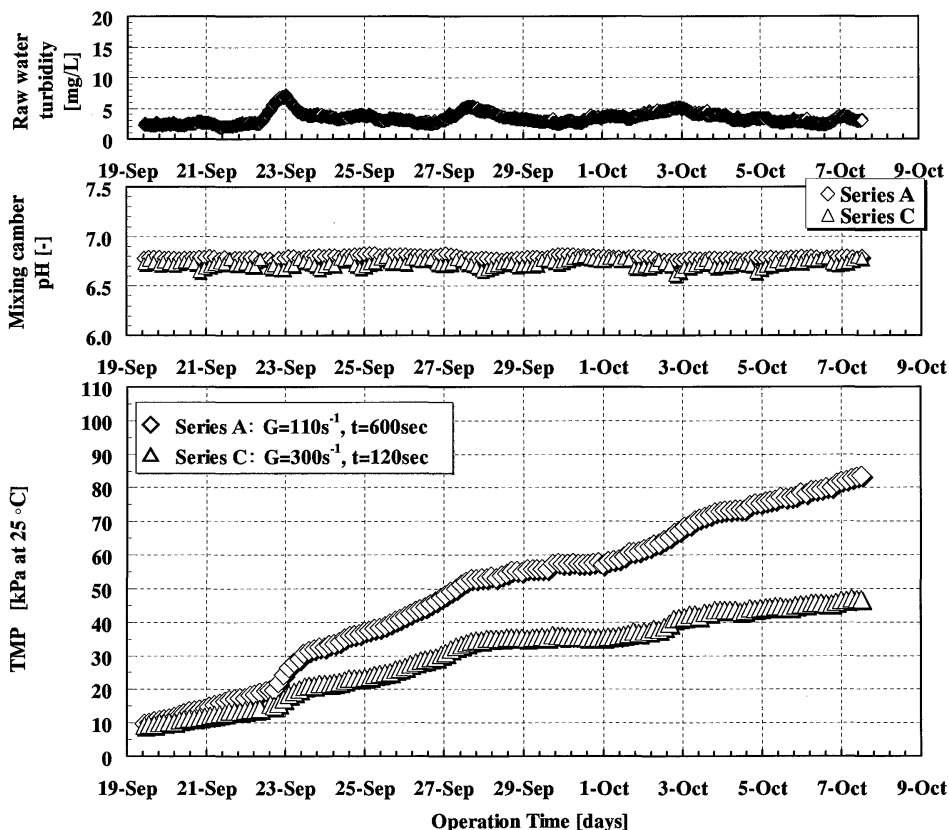

Fig. 3 Membrane filtration performance in the optimum coagulation range

(2) Verification of the effect of the optimum Gt range of coagulation

Verification of the effect of the optimum Gt range of coagulation will be given and discussed from the following aspects.

a) Membrane filtration and filtrate quality

Figure 3 shows the profiles of raw water turbidity, mixing chamber pH and TMP with running time for the run of Series A with the Gt value of 66,000 ($G=110\text{ s}^{-1}$, $t=600\text{ sec}$) and the run of Series C with the Gt value of 36,000 ($G=300\text{ s}^{-1}$, $t=120\text{ sec}$). For both runs, the filtration flux was $4\text{ m}^3/\text{m}^2/\text{day}$, the physical cleaning interval was 3 hours and the coagulant dosage was 20 mg/L as PACl.

As is evident from this figure, TMP of the Series C with the Gt value of 36,000 ($G=300\text{ s}^{-1}$, $t=120\text{ sec}$) was always lower than the Series A with the Gt value of 66,000 ($G=110\text{ s}^{-1}$, $t=600\text{ sec}$). The increasing extent of TMP during the time of raw water quality deteriorations due to rainfall (for instance, around Sep. 23), as could be seen from the time profile of the raw water turbidity, was also smaller. After running for three weeks, the difference in TMP was nearly two-folds.

Table 5 Water quality before and after filtration (Samples of 2008/09/21)

	unit	Raw water	Series A filtrate	Series C filtrate
pH	-	7.2	7.1	7.0
Temperature	°C	15.0	14.0	14.0
Turbidity	mg/L	9.0	<0.1	<0.1
Color	degree	2.6	0.9	0.7
Total Fe	mg/L	0.12	<0.01	<0.01
Soluble Fe	mg/L	0.03	-	-
Total Mn	mg/L	0.012	0.002	0.002
Soluble Mn	mg/L	0.001	-	-
Total Al	mg/L	0.10	0.03	0.01
Soluble Al	mg/L	0.01	-	-
TOC	mg/L	2.4	0.7	0.7
DOC	mg/L	1.1	-	-
UV260	1/5cm	0.151	0.063	0.060
G value	s^{-1}	-	110	300
Mixing time	sec	-	600	120

The analytical results of water quality in the course of filtration are shown in Table 5. For TOC, the values were confirmed to be of the same level in filtrate of both series runs. However, for the index of

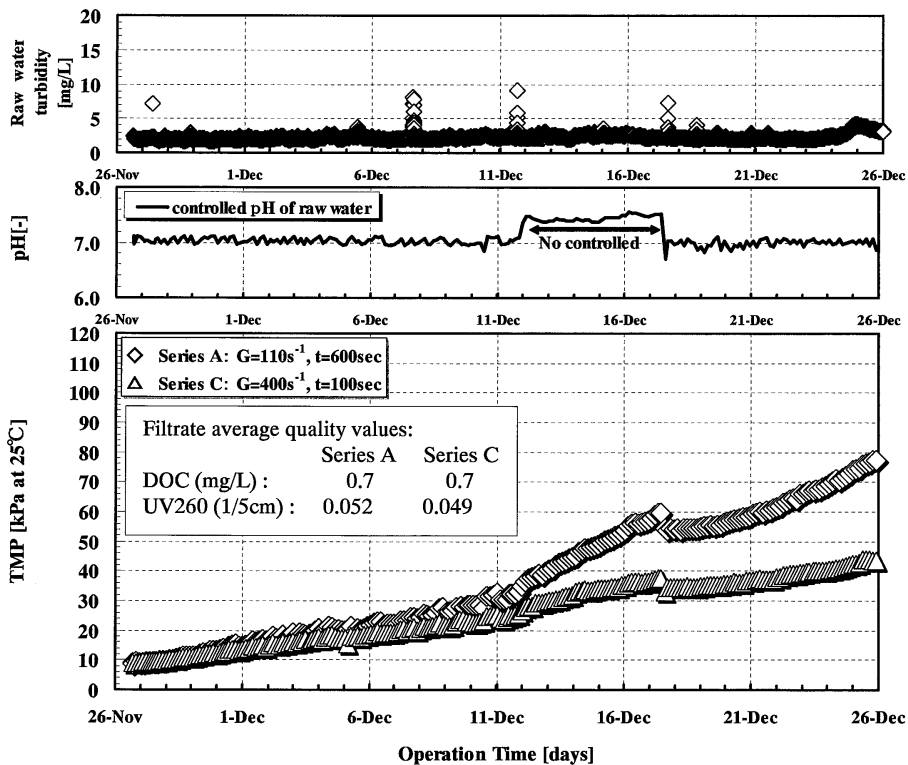

Fig. 4 Membrane filtration performance under varied pH

UV260 and the index of total residual Al, the filtrate of the Series C with the Gt value of 36,000 ($G=300\text{ s}^{-1}$, $t=120\text{ sec}$) revealed lower values than the Series A with the Gt value of 66,000 ($G=110\text{ s}^{-1}$, $t=600\text{ sec}$). Given the mixing time of coagulation is sufficient, a mixing strength that could lead to a Gt value falling in the optimum Gt range of about 20,000-50,000 seems to be effective to alleviate the development of TMP. Enhanced capture of humic molecules detected by UV260 and aluminum onto and/or into coagulated flocs, and thus reduced levels of these fouling causing substances in the water after coagulation, as could be estimated from the filtrate water quality, might be the reason behind the better performance with the run of Series C. For verification, as mentioned earlier that further investigation of the physicochemical characteristics of flocs and the remaining constituents not captured by flocs under different mixing conditions of coagulation is necessary.

Thomas et al. [12] reported that the residual aluminum concentration decreases with increases of the mixing time. Even if our result did not support their result, the difference in the mixing strength G might be a reason and it is evident that the

coagulation condition affects the performance of membrane filtration.

b) Responses of membrane filtration to variation of water pH

The variations of pH and turbidity in the water to be treated and the TMP development with time are shown in **Figure 4**. The coagulant dosage was controlled identical at 20 mg/L (as PACl). For most time of the experiment, pH of the raw water was controlled at 7.1. A running period without pH adjustment was allowed for about one week. During this week, pH of the raw water was slightly higher, the values of which were about 7.5. The physical cleaning interval and the flux were maintained not changed: 3 hours and $4\text{ m}^3/\text{m}^2/\text{day}$, respectively.

It can be seen from the figure that TMP in Series A with the Gt value of 66,000 ($G=110\text{ s}^{-1}$, $t=600\text{ sec}$) suddenly increased for the period from December 11 to December 17 when pH was not controlled. However, for Series C with the Gt value of 40,000 ($G=400\text{ s}^{-1}$, $t=100\text{ sec}$) that fell in the optimum coagulation Gt range shown in Figure 2 suffered less changes in the increasing pace of TMP. Lowering water pH within a certain range was found to be able

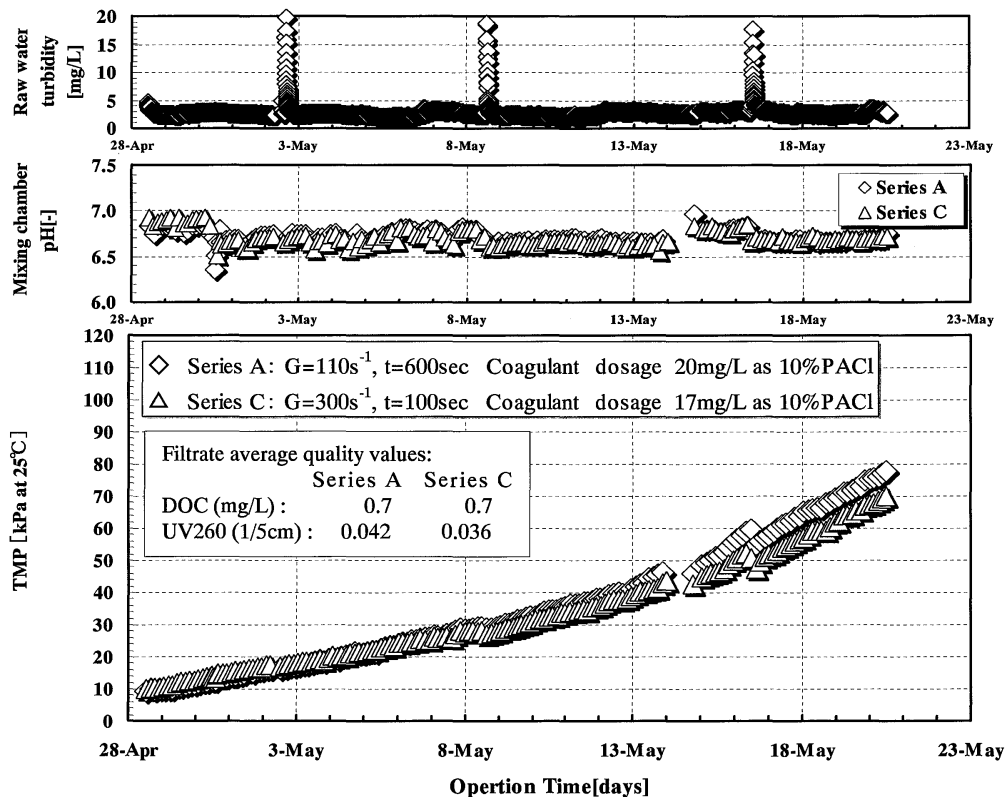

Fig. 5 Membrane filtration performance when coagulant dosage was reduced

to enhance the content of humic molecules captured into micro flocs coagulated by either Al or Fe coagulant [13]. Taking into consideration this finding, it is reasonable to consider that the observed increases in the trend of TMP during the period of higher pH were caused partly, if not totally, by those humic molecules that were not coagulated under higher pH; and coagulation under the condition with a suitable Gt probably reduced the remaining level of such fouling causing molecules (as could be estimated from the lower average UV260 value in the filtrate shown in Fig. 4). The likely differences in the physicochemical characteristics of flocs and residual Al species in the water after coagulation under these two different conditions may also contribute to the observed difference, for which investigation is desired and will be done in coming studies. The results shown in this figure further suggest the adversary influence of raw water quality variation on the development of TMP can be minimized by optimizing the coagulation conditions during membrane filtration.

c) Effect to reduce coagulant dosage

Comparisons of the performance of membrane filtration under two different coagulant dosages are shown in **Figure 5**. For the run of Series A with a Gt value of 66,000 ($G=110\text{ s}^{-1}$, $t=600\text{ sec}$), the dosage of coagulant was set at 20 mg/L. For the run of Series C with a Gt value of 30,000 ($G=300\text{ s}^{-1}$, $t=100\text{ sec}$), the coagulant dosage was set at 17 mg/L. For both runs, pH was controlled identical, the physical cleaning interval during the runs was 3 hours and the filtration flux was $4\text{ m}^3/\text{m}^2/\text{day}$.

In the first half of the running period lasted for about 2 weeks (from April 28 to May 13), both runs showed an increasing trend of TMP similar to each other. Apparent differences in the trend appeared in the second half that lasted for more than 1 week till May 21, with the increasing rate of TPM for the run of Series C with the Gt value of 30,000 ($G=300\text{ s}^{-1}$, $t=100\text{ sec}$) being apparently smaller than that for the run of Series A with the Gt value of 66,000 ($G=110\text{ s}^{-1}$, $t=600\text{ sec}$). Enhanced reduction of the remaining level of fouling causing humic molecules in the water after pre-coagulation under the Gt value of 30,000 (as could be estimated from the lower average UV260 value in the filtrate shown in this figure), even at the lower coagulant dosage, might be the reason for result observed. However, since irreversible fouling caused by Al was also conceivable, the effect due to the lower coagulant dosage could not be excluded. Comparative runs under identical Gt values are desired, which will be included in coming studies. Even so, the result

obtained suggests that by adopting a Gt value within the optimum range observed in this study, the reduction of the coagulant dosage can probably be realized without sacrificing the filtration performance in regarding the development of TMP.

4. CONCLUSIONS

Based on the results of long term pilot scale membrane filtration experiments with pre-coagulation to treat the Kiso River water, following conclusions can be drawn.

1) Coagulation under suitable mixing strength and time was important to control the development of irreversible membrane fouling when coagulation was used as a pretreatment process to treat surface water used as the water source of conventional water purification plants. Over the Gt ranges of 2060-180,000 investigated in this study from selected combinations of G in the range of 30-1375 s^{-1} and the mixing time t of 1.5-2.5 sec, an optimum coagulation range that could suppress the increasing rate of TMP seemed to be existent in the range about 20,000-50,000. This range is narrower than the range of 6,000-60,000 suggested in the Guideline on Design of Water Supply Facilities [11] and can be used as a reference for facilitated determination of suitable pre-coagulation conditions. Gt values below 10,000 associated with larger values of the relative increase rate of TMP.

2) Pre-coagulation with optimum Gt values alleviated the influence of variations in raw water quality on the development of irreversible membrane fouling during filtration and could reduce the coagulant dosage.

To clarify the mechanisms involved behind the effect of Gt investigated in this study, detailed studies on the physicochemical characteristics of flocs in such aspects as sizes, composition and charge densities, and the physicochemical composition of remaining constituents not captured onto/into flocs after coagulation are necessary, along with floc interactions with membrane, and will be conducted in coming studies.

REFERENCES

- 1) A.M. Jack, M.M. Clark, Using PAC-UF to treat a low-quality surface water, *J. AWWA*, Vol. 90, No. 11, pp. 83-95, 1998.
- 2) C. Guigui, J.C. Rouch, L. Durand-Bourlier, V. Bonnelye, P. Aptel, Impact of coagulation conditions on the in-line coagulation/UF process for drinking water production, *Desalination*, Vol. 147, pp. 95-100, 2002.
- 3) S.H. Lee, B.C. Lee, S.Y. Moon, Y.S. Choi, N.Y. Jang, Y. Watanabe, Evaluation of a MF membrane system composed of pre-coagulation-sedimentation and chlorination for water reuse, *Water Sci. Technol.*, Vol. 54 (10), pp. 115-121, 2006.

- 4) A.A. Karimi, J.C. Vickers, R.F. Harasick, Microfiltration goes Hollywood: the Los Angeles experience, *J. AWWA*, Vol. 91, No. 6, pp. 90–103, 1999.
- 5) A. Maartens, P. Swart, E. P. Jacobs, Feed-water pre-treatment: methods to reduce membrane fouling by natural organic matter, *J. Membr. Sci.*, Vol. 163, pp. 51–62, 1999.
- 6) K.J. Howe, A. Marwah, K.-P. Chio, S.S. Ahham, Effect of coagulation on the size of MF and UF membrane foulants, *Environ. Sci. Technol.*, Vol. 40, pp. 7908–7913, 2006.
- 7) Kevin Young-june Ohoi, B.A. Dempsey, In-line coagulation with low-pressure membrane filtration, *Water Research*, Vol. 38, 4271–4281, 2004.
- 8) K. Kimura, T. Maeda, H. Yamamura, Y. Watanabe, Irreversible membrane fouling in microfiltration membranes filtering coagulated surface water, *Journal of Membrane Science*, Vol. 320, pp. 356–362, 2008.
- 9) Standard Methods for Examination of Water, Japan Water Works Association, Tokyo, Japan, 2001.
- 10) Yuka Ando, Investigation of coagulation conditions for controlling membrane filtration resistance, Master thesis of Gifu University, 2008.
- 11) Guidelines on Design of Water Supply Facilities, Japan Water Works Association, Tokyo, Japan, 2000.
- 12) Thomas Myne, Johannes Altmann and Tor Ove Leiknes, the 9th International Conference on Membranes in Drinking and Industrial Water Treatment, June 2010, Trondheim, Norway.
- 13) F.S. Li, A. Yuasa, Y. Ando, Characterization of micro-flocs of NOM coagulated by PACl, alum and polysilicate-iron in terms of molecular weight and floc size, *Water Sci. Technol.*, Vol. 57, No. 1, pp. 83–90, 2008.

(Received May 25, 2012)